

In-Rail-Bus

Spring contact block 5-poles for horizontal pcb

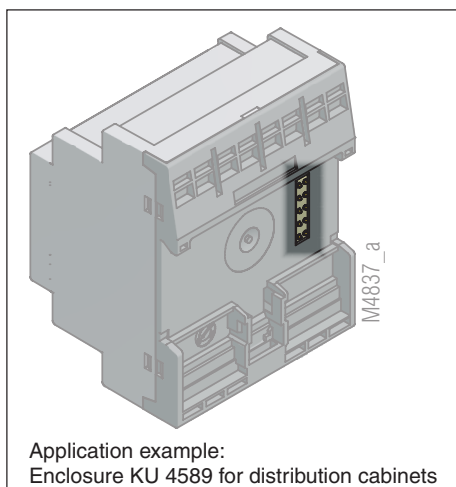

Approvals and Markings



*) in preparation

Your Advantages

- Modular, flexible for horizontal pcbs
- Reliable and consistent supply, connection and distribution of energy, signals and data

Features

- Universal use with various enclosure types
- High current (5 A per bus pcb-rail)
- Quick and easy mounting in the DIN-rail
- Contour and layout of the bus pcb can be according to customers' requirements e.g. defined by the customer
- Designed for standard DIN-rail dimensions
- Large stand-off to DIN-rail floor allows the mounting of SMD components on the bus pcb underside
- The carrier profile is securely fixed by safety caps (left and right) on the DIN-rail

Carrier profile 15 Carrier profile 7.5

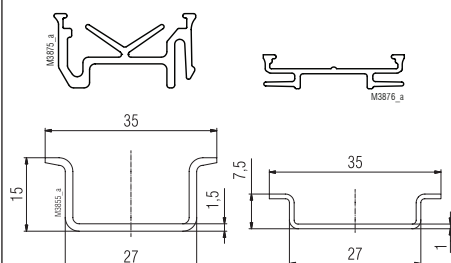

- Pcb rail "breaks" are possible, e.g. for operation of bus signals inside instruments

Technical Data

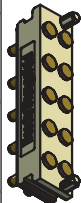
Type	Contact pins	
KO 4303-400	5	 <p>M4838_a</p> <p>Pic. 10 pins</p>
KO 4303-400.1	10	
KO 4303-400.2	7	

Enclosure material: Polyamid PA46

Temperature stability	
compl. with EN 75-1/2 (1.8 MPa):	290 °C
compl. with EN 75-1/2 (0.45 MPa):	290 °C

Flame retardancy

complying with UL 94: V-0

Bus rails: 5

Contact material: copper tinned, gold plated

Max. contact resistance

Spring contact block - bus element: typically: $\leq 20 \text{ m}\Omega$

Max. current carrying capacity: 2.5 A per spring contact pin
5 A two contact pins per potential necessary
25 A (max. total current)

Spring contact on bus element: at 0.7 mm working stroke 85 cN

Spring contact block fixing: by reflow solder method

Creepage current resistance: CTI 325 $\hat{=}$ insulating material III a IEC 60 664-1

Air gap: $\geq 0.8 \text{ mm}$ IEC 60 664-1

Creepage distance: $\geq 2.0 \text{ mm}$ IEC 60 664-1

Voltage U_{eff} : 63 V

Overvoltage category: II

Rated impuls voltage U_{Bem} : 0.8 kV

Pollution degree: 3

More informationen
see datasheet
In-Rail-Bus

Dimension spring contact block

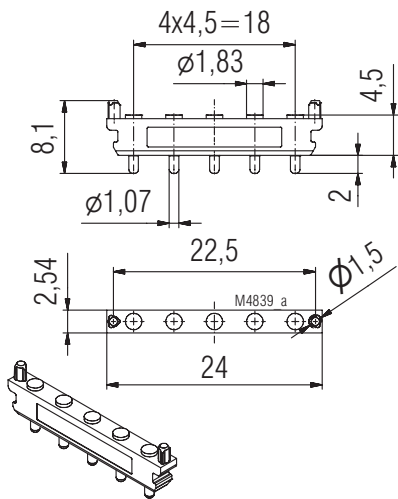

Spring contact block KO 4303-400

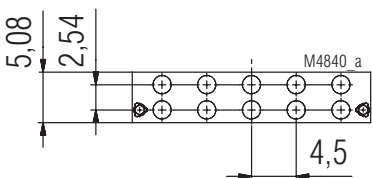

Spring contact block KO 4303-400.1

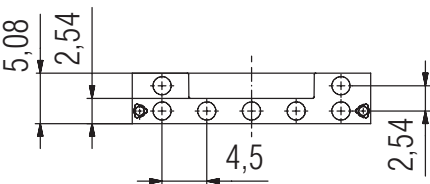

Spring contact block KO 4303-400.2

Permitted installation positions for the spring contact block in the enclosure bottom between $H = 4,5 \dots 5,4$ mm

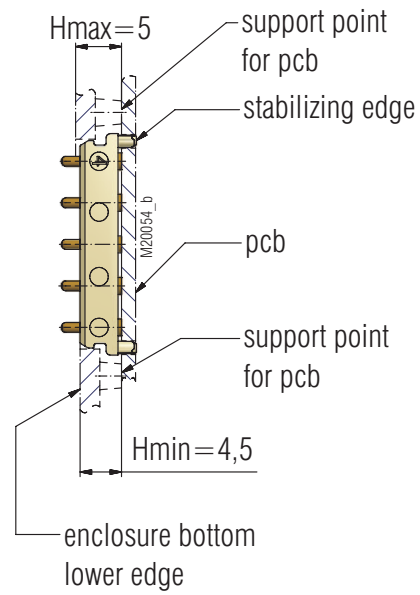

Installation example

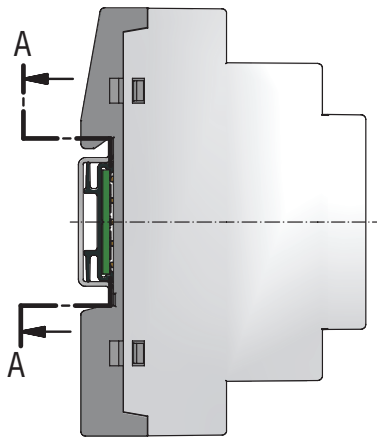
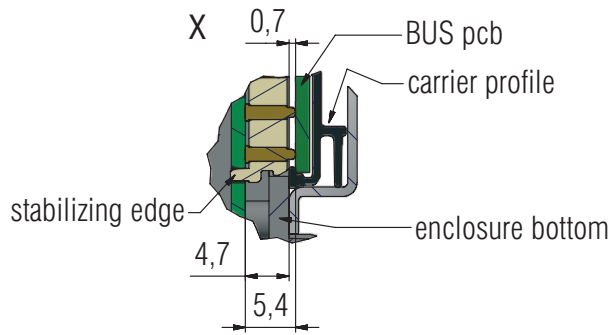
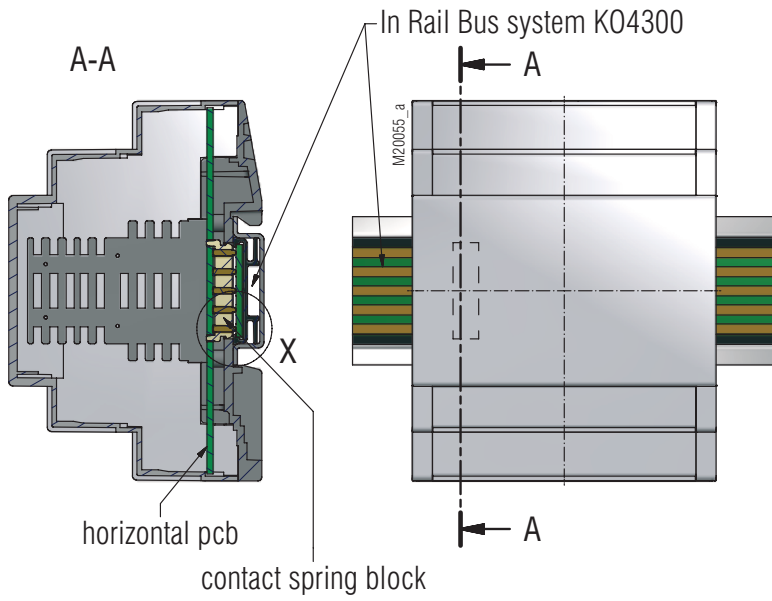

A-A

